

'BOG-SKIPPER' (20 TONNE CAPACITY)



20 tonne capacity ultra-low ground pressure 'Bog-Skipper'

Lankelma's lightweight, ultra-low ground pressure 'Bog-Skipper' is a compact, robust and flexible unit ideal for Cone Penetration Testing operations on soils with marginal stability and bearing capability.

The unit is fully self-contained, being supplied with a dedicated hydraulic power pack, generator and data logging system.

The unit is 6.5 tonne and can be fitted with either 10 or 20 tonne capacity hydraulic rams.

Unlade, the unit has a ground bearing pressure of approximately 15kPa.

The unit is highly flexible in its capability to work in marginal environments. Typical applications include:

- ❑ Marshlands
- ❑ Intertidal mudflats and beaches
- ❑ Embankments
- ❑ Tailings dams
- ❑ Earthworks site
- ❑ Soils with high liquefaction potential



'BOG-SKIPPER' (20 TONNE CAPACITY)



The dimensions of available rams are detailed below:

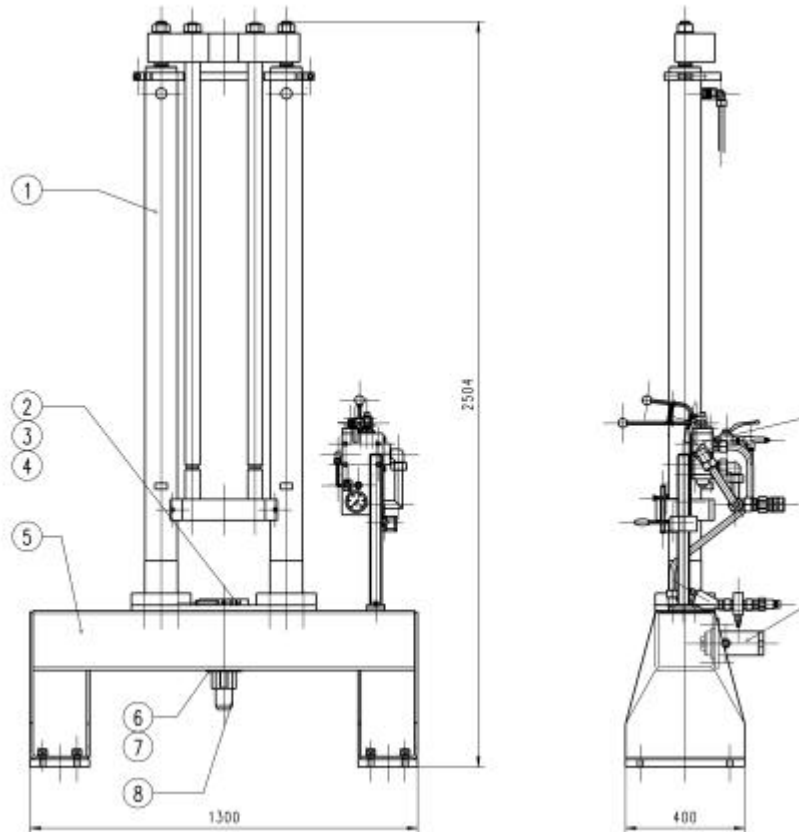

The system is capable of operating the full range of both standard and specialist cones, together with MOSTAP soil sampling and instrumentation installations provided by Lankelma.

For the details on cost, performance and availability of this unit please contact:

Lankelma CPT Limited
The Old Dairy
Wittersham Road
Iden
East Sussex
TN31 7UY

Tel: + 44 (0) 1797 280050
Fax: + 44 (0) 1797 280195

Lankelma CPT Limited
Unit 31 Deeside Industrial Estate
Welsh Road
Deeside
CH5 2LR

Tel: + 44 (0) 1244 289356
Fax: + 44 (0) 1244 285357